

# FLAME TECH<sup>®</sup>

## Scorpion Track Torch

Cutting & Welding Track Machine

FT-STT and FT-STT-HD

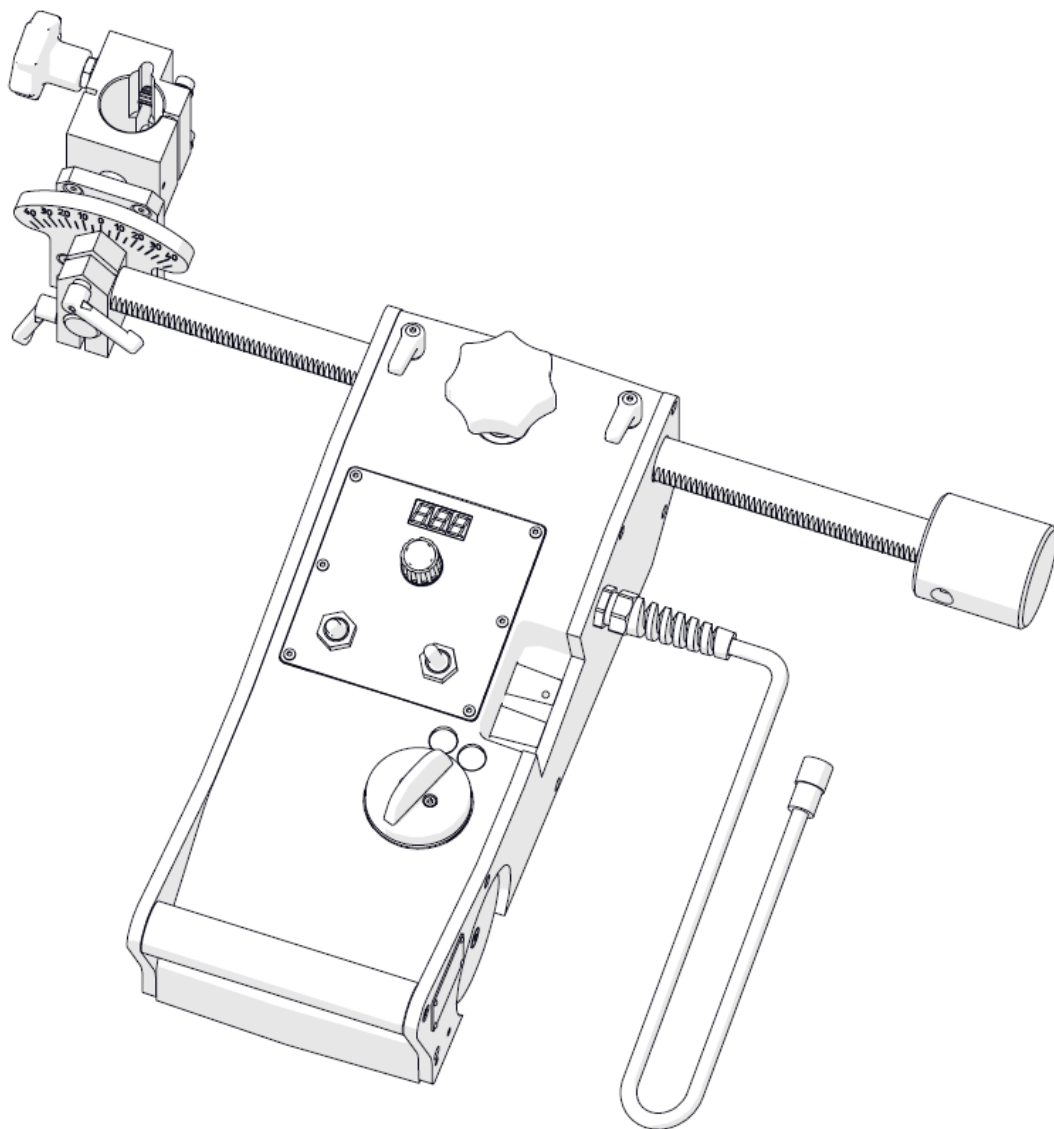

# 1 GENERAL INFO

## Foreword

This document contains info about the general use of the Flame Tech Track Torch cutting machine. The machine is built exclusively for use with oxyfuel, plasma cutting, and welding equipment. Optional additional equipment is also available from Flame Tech. Using the machine for purposes other than the described operations is considered contrary to its designated use. The user will be solely reliable for all risks and hazards resulting from the use of the machine. The machine is designed for use on flat and level materials. Other special materials or configurations are not specifically approved by Flame Tech. The machine is designed to work efficiently, safely, and precisely over a period of many years. This can only be guaranteed if the instructions regarding operation, maintenance, and service are observed. The machine may be used, maintained, and repaired only by persons who are familiar with such work and have been instructed on correct repair and operating procedures. Unauthorized modifications to the machine will result in the forfeiture of all damage and/or warranty claims against Flame Tech for any damage resulting from such modification. The user must ensure that all safety devices are in working condition and check them for proper functioning at regular intervals. Only the use of spare parts and consumables specified by Flame Tech guarantees the machine will operate as expected under normal conditions.

### **Note!**

We strongly advise against installing parts which have not been provided or approved by Flame Tech. Installation of such parts may negatively impact the operation of the machine. Flame Tech will not be held liable for any damage resulting from the use of non-approved parts, accessories, or modifications.

Revision Date: 12/17/2025

### Technical data

	Scorpion Track Torch
Voltage	1~ (Single Phase) 115–230 V, 50–60 Hz
Power	20 W
Standard Torch Diameter	0.315 in (5/16")
Speed	0–60 in/min
Weight	37 lbs

### General Dimensions

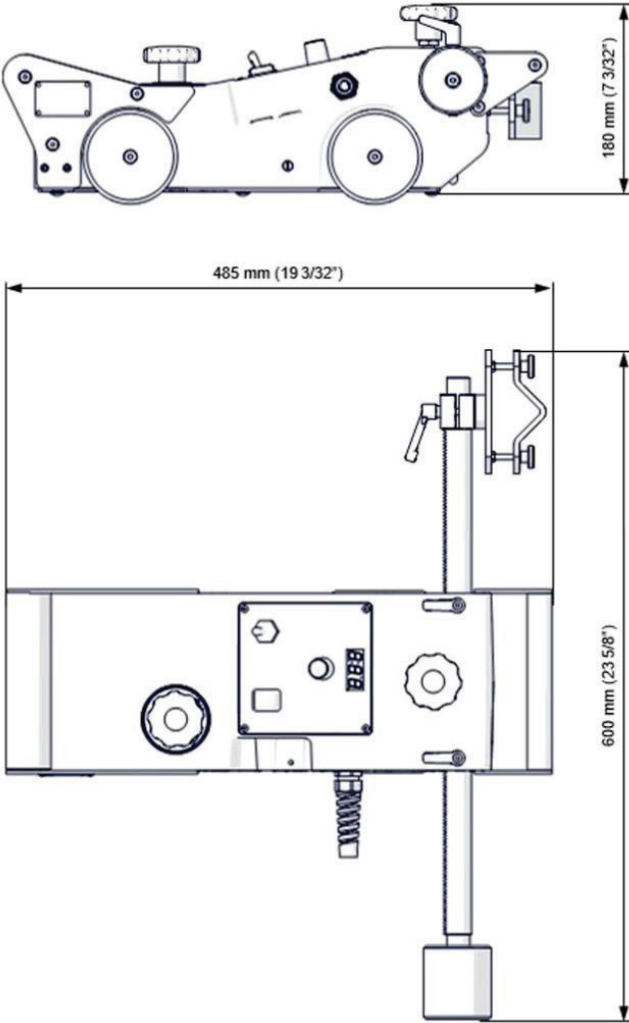

## Scorpion Track Torch (FT-STT) Parts List

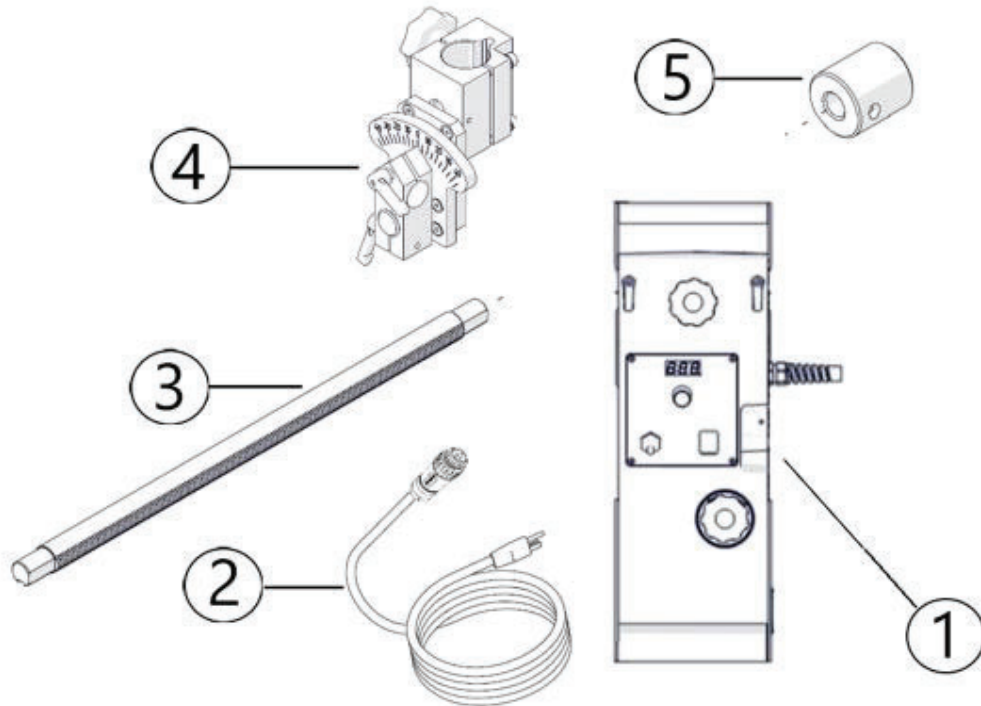

Parts List		
Item	Part Description	Part Number
1	Base, Torch Machine FT-STT	77795001
2	Power Cord, 110V US	77795002
3	Arm, 21 Inch	77795003
4	Precise Machine Torch Holder, 1-3/8" (35mm)	77795006
5	Counterweight 2.8 lb	77795004

## Scorpion Track Torch Heavy Duty (FT-STT-HD) Parts List

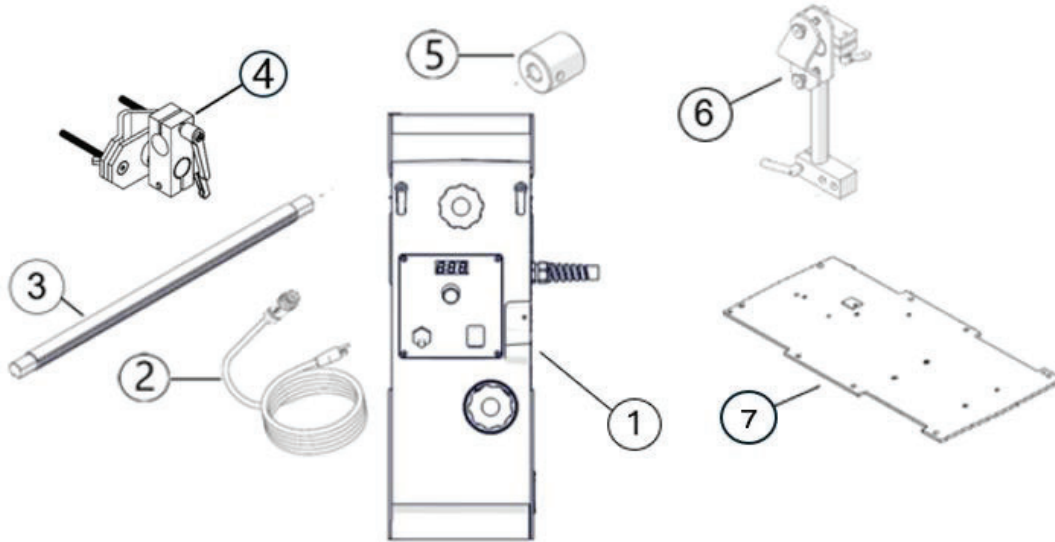

Parts List		
Item	Part Description	Part Number
1	Base, Torch Machine FT-STT	77795001
2	Power Cord, 110V US	77795002
3	Arm, 39 Inch	77795009
4	HD Universal Mount	77795020
5	Counterweight 5.7 lb	77795010
6	Guide Arm Assembly, Hoses	77795007
7	Bottom Heat Shield	77795015

**Accessories** (sold separately)

**1. V-Groove Track Section, 70"**

Track assemblies can interconnect to form various lengths

Part Number: 77795008

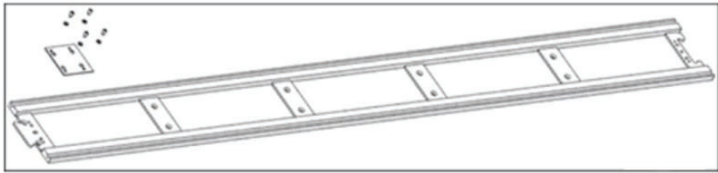

**2. Manifold, 2 in x 3 out, CGA B**

Input and output for hoses with on/off valve

Part Number: 77795013

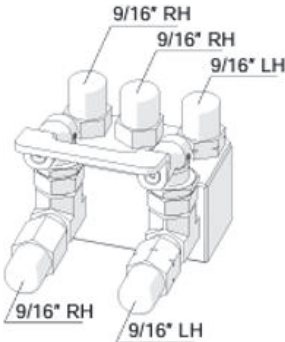

**3. Oxygen and Fuel Hoses with Strain Guard, 4'**

Connects to the torch and the manifold

Part Numbers: 71838041 (Oxy,Green); 71838042 (Fuel, Red)

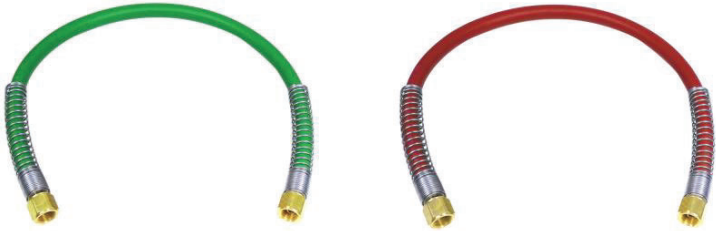

## Spare Parts List

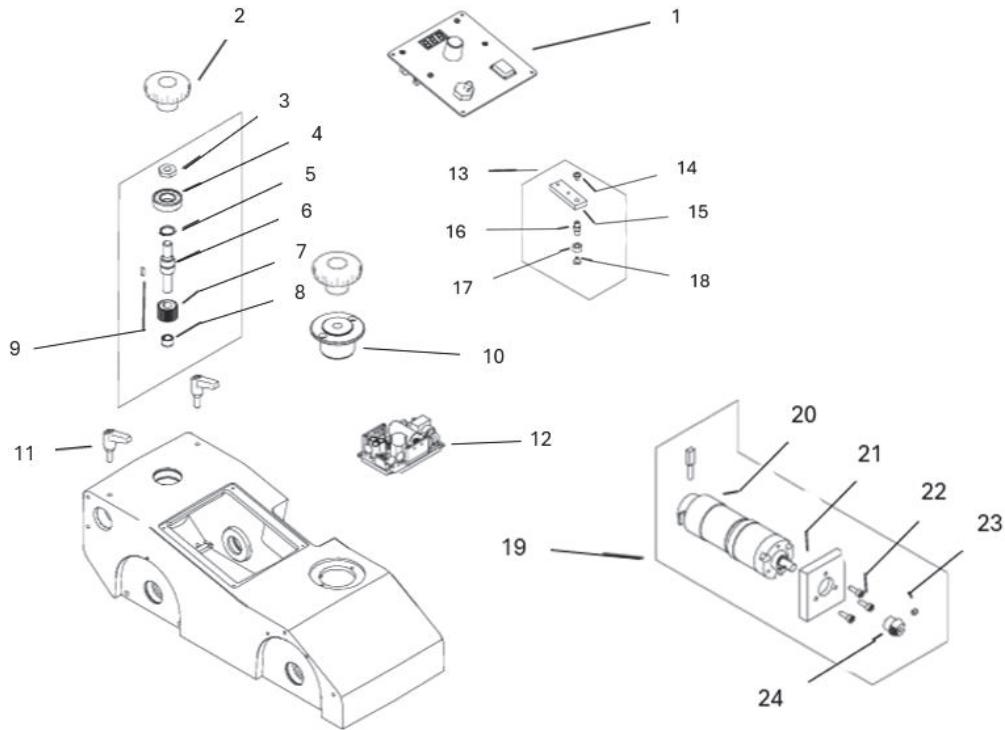

Item	Part Description	Part Number	Quantity
1	Control Panel, FT-STT	77795021	1
2	Star Knob, FT-STT	77795022	2
3	Low Hex Nut M10, FT-STT	77795023	1
4	Ball Bearing, FT-STT	77795024	1
5	Retaining Ring, FT-STT	77795025	1
6	Gear Shaft, FT-STT	77795026	1
7	Gear, FT-STT	77795027	1
8	Slide Bushing, FT-STT	77795028	1
9	Parallel Key, FT-STT	77795029	1
10	Clutch Knob, FT-STT	77795030	1
11	Handlever, FT-STT	77795031	2
12	Power Supply Unit, FT-STT	77795032	1
13	Switch Arm Assembly, FT-STT	77795033	1
14	Button Head Screw M4x6, FT-STT	77795034	1
15	Switch Arm, FT-STT	77795035	1
16	Shaft, FT-STT	77795036	1
17	Sleeve, FT-STT	77795037	1
18	Button Head Screw, FT-STT	77795038	1
19	Motor Assembly, FT-STT	77795039	1
20	Motoreducer Assembly, FT-STT	77795040	1
21	Motor Bracket, FT-STT	77795041	1
22	Socket Cap Screw M4x12, FT-STT	77795042	3
23	Socket Cap Screw M5x5, FT-STT	77795043	1
24	Cog, FT-STT	77795044	1

## 2 SAFETY PRECAUTIONS



### CAUTION!

**This manual does NOT include information related to the safe and correct operation of Oxy-Fuel cutting torches and related equipment and accessories. Proper knowledge and training of your specific gas delivery system and cutting equipment is essential for the safe operation of this machine. Refer to your equipment literature or training to ensure all safety protocols are in place for the safe operation of your specific equipment.**

**If you are unsure about any aspect related to the safe use of flammable gases, high pressure cylinders, regulators, flashback arestors, cutting torches, and other related equipment required to safely operate a cutting torch, do not proceed.**

**Seek out proper training on the required safety protocols required for your specific application and equipment.**

1. Before use, read this Operator's Manual and complete a training course in occupational safety and health. Ensure you are wearing the correct PPE for your application and environment.
2. Use only for applications specified in this Operator's Manual.
3. Inspect the machine for missing parts and damage.
4. Make sure the power source matches the machine requirements.
5. Ensure your power source is properly grounded.



6. Do not move the machine by the cords, cables, or hoses and do not pull on them. This can cause damage that is not immediately apparent and can create a dangerous situation.
7. Keep untrained bystanders away from the working area.
8. Before every use, inspect the machine. It may not be in the configuration or condition that you are expecting. It is your responsibility to operate the machine safely and responsibly.
9. Keep the machine dry. Do not expose the carriage to rain, snow, fog, mist, or other wet environments.
10. Keep the work area well lit, clean, and free of obstacles.
11. Do not use near flammable materials, or in explosive environments.
12. Only transport and position the carriage by using the carrying handle or the main body.
13. Do not stand underneath a machine that may be operating in an elevated area.
14. Keep the power cord connection sockets clean.
15. Do not use high pressure water or air to clean the machine.
16. Only use a torch that fits securely into a matching torch holder.
17. Keep the torch cables away from hot surfaces. Organize cords and cables to decrease the load applied on the carriage.
18. Be familiar with the safe and proper operation of your cutting torch, plasma torch, or welding machine, as described by the manufacturer's instructions.
19. Keep the carriage in a horizontal position during work.
20. Be sure that any other potential operators of this machine are trained properly.
21. Do not stop the carriage by hand. To stop machine travel, set the clutch to OFF or the direction switch to 'Off'.
22. Only allow authorized personnel to make repairs to this machine.
23. If any part of the machine is not working correctly, stop the work immediately and determine the source of the failure. Report the issue and seek repair from authorized personnel.
24. Do not leave the machine running unattended.
25. If your machine is not being used, safely store it away from active work areas in a dry location. Do not leave the machine out when not in use.

### 3 OPERATION

Connect the plastic twist connector on the power cord to the matching end on the machine power cord. The sockets have an alignment notch that only allows installation in the correct position. Align the plug ends, press together firmly, and then twist the threaded collars together.

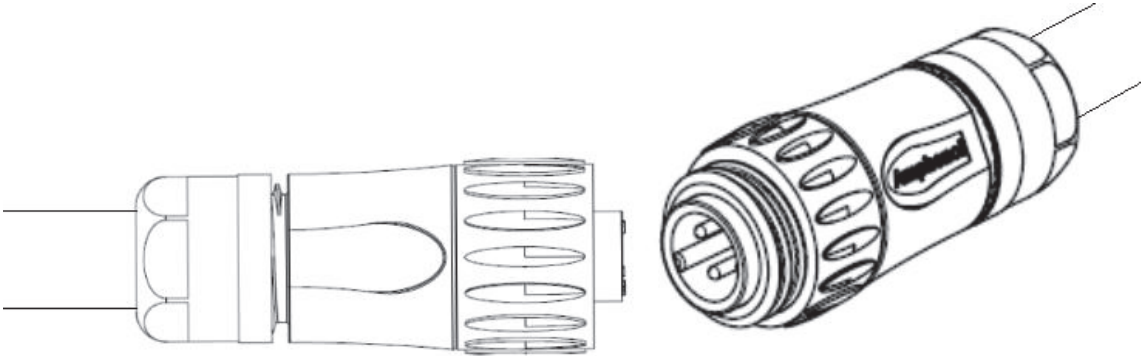

Before the initial use remove the protective anti-corrosion material from the V-grooves in the track using a solvent cleaner. Place the torch track section(s) onto your workpiece material.

The track must be flat and level for proper operation of the drive wheels in the track.

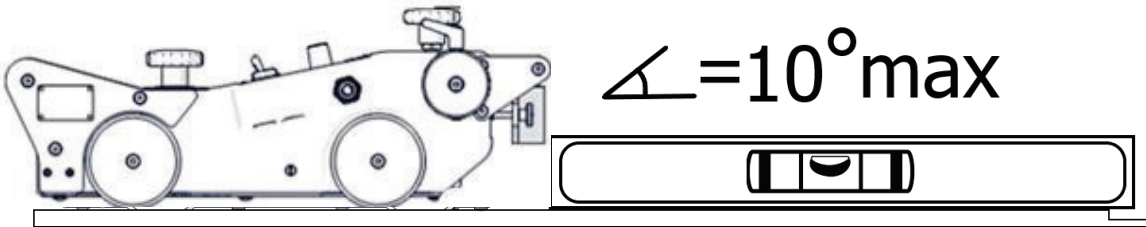

Use the carrying handle to transport the machine to the work area and onto the torch track. Place the machine on the rail and assemble your torch holder, arm, and counterweight assembly, and any other accessories, as required by your application. Please note that the adjustable handles for the arm and torch holder can be lifted to rotate freely and released to engage and tighten.

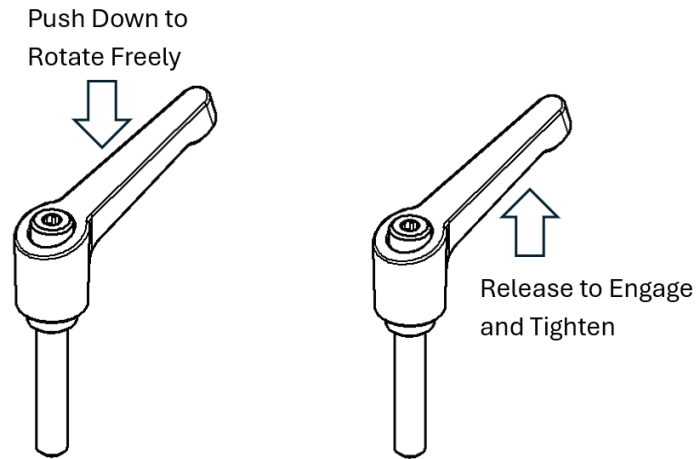

Adjust the track into position and make sure there is enough track to travel the entire length of your desired cut. Leave yourself additional space before and after the desired cut length for extra travel of the track machine without allowing it to run off the track.

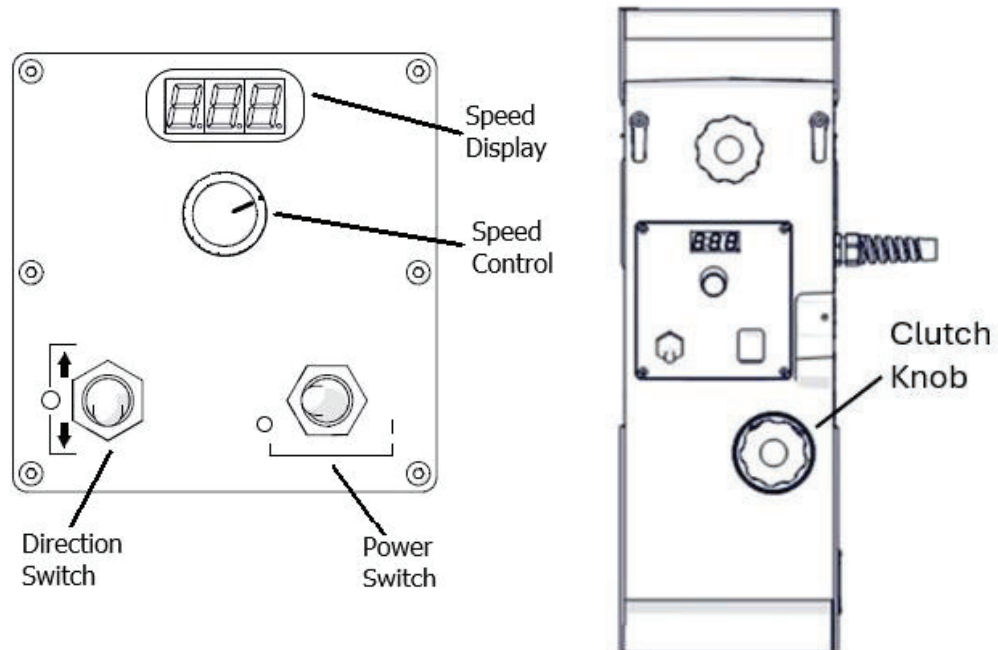

Set the power switch to 'I' to turn on the machine. Then, the display comes on (888) and the display will momentarily show *US*. Next, the travel speed shows. Use the speed knob to set the desired speed. If needed, set the clutch knob to OFF and travel the machine by hand to your starting location.

To start torch cutting, light your torch according to the manufacturers recommended procedures, and set the cutting flame to the desired flame profile for preheating.

With the clutch engaged, and the direction switch set to 'O', use the direction switch to set the machine in motion in the direction of travel. Then, the travel speed shows on the display. To stop the travel, set the direction switch to 'O' or the clutch to OFF. Extinguish the torch flame according to your torch requirements.

After the work is finished, use the power switch to turn off the machine and unplug the power cord from the power source. The power cord socket connector can be left connected, or disconnected for ease of transport and storage. Keep the V-grooves of the track clean and free from debris. If you need to store the tracks for an extended period, apply a protective anti-corrosion coating to the V-groove to prevent rusting of the precision machined V-groove. Pitting, corrosion, debris, or other imperfections in the V-grooves can cause uneven cutting when the wheels ride over imperfections or debris during travel.

**4 TROUBLESHOOTING**

<b>Message</b>	<b>Problem</b>	<b>Solution</b>
0.55.	Display not fully on after powering.	Contact service center for check and repair.
EUR	Speed shown in centimeters per minute instead of inches per minute.	Refer to the section "Changing the unit of speed."
USA	Speed shown in inches per minute instead of centimeters per minute.	Refer to the section "Changing the unit of speed."
Er.5.	Direction switch not set to 'O' when powering.	Set the direction switch to 'O'. If the message still shows, contact service center for check and repair.
	Shown during travel indicates a malfunction.	Contact service center for check and repair.
crL	Motor overload. The carriage stops.	Adjust the position of the cables so that they do not block the carriage. Remove other objects that block the carriage or its wheels. If this message still shows, contact service center for check and repair.